



Perfect binder

**Ligo**



# Ergonomic. Origamic.



The lines and ergonomics of the new Mamo series are inspired by the shapes and design of **Origami**. Ancient as Japan's culture. Modern as a minimalist artwork. Simple and sophisticated, like all things that endure and hold value.

The **Ergonomics** of the new Mamo are machines that ensure greater productivity and less waste of materials and time. No maintenance is required, machine management and control can also be handled remotely. Mamo's internally designed software constantly monitors productivity, ensuring the machine's efficiency is always guaranteed.

# Ligo

**Ligo** is a product that offers extraordinary ease of use. Each design element, meticulously crafted with decades of printing industry knowledge, prioritizes practicality, comfort, and functionality. Engineered ergonomic features ensure accessibility and streamline operation, reducing operator stress and maximizing productivity and output quality. Additionally, the display design is intuitively simple and functional, facilitating seamless operation. Technology and aesthetics, function and design fused into an original product with its personality, full of new possibilities waiting to be explored.





# Working has never been so intuitive!



**Ligo** is the ideal solution for printing houses and digital print shops that need to manage the perfect binding of digital prints in-house. It uses EVA glue and has been developed to consistently ensure the highest quality in binding, even during intense and continuous operations. Using Taca Pro glue, it can effectively bind coated papers with weights up to 160 gsm. It supports binding with soft covers, hard cardboard covers (up to 2.8 mm thick), and notepad binding (coverless), with a block thicknesses ranging from 1 to 50 mm.



mammo



# Your binding has never been so perfect

With **Ligo**, a perfectly squared spine is always guaranteed, regardless of the thickness of the book, pre-creasing is not necessary, thanks to the force applied by the cover clamp, which is fully adjustable from the touchscreen. The machine is equipped with both a notching tool and a milling blade to enhance glue adhesion or to separate the signatures before binding.

All settings can be managed in a few seconds directly from the large and intuitive touchscreen display. LIGO automatically adjusts the work cycle speed based on the thickness of the inserted block to ensure correct notching and gluing (the depth of notching is managed by software).



The adaptive side gluers, automatically adapt to the book thickness and do not require any manual adjustment. Among the features of the new software, the possibility to obtain production reports and integrating the machine in an Industry 4.0 perspective. The innovative user interface allows an optimal user experience by guiding the operator in setting the optimal parameters required for each process with extreme ease.

#### **Remote management:**

Management and control have been studied so that the machine is remote controllable in all functions. Working has never been so convenient.

#### **Technology 4.0:**

The software has been designed by Mamo. It's continuously updated and in evolution with an interface graphic extraordinarily intuitive.

#### **Productivity control:**

The internal software constantly checks and monitors the productivity so that machine efficiency is permanently guaranteed. A real advantage.

# Intelligence 4.0



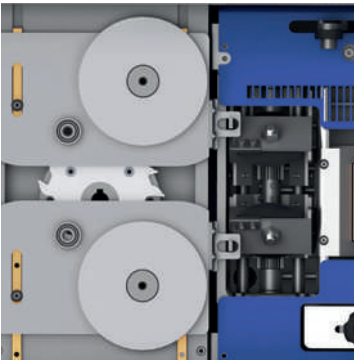

# The engineering valuable retail

The glue tank with side gluers is an added value supplied to Ligo, this system designed to facilitate the application of glue in a precise way both on the back and on the sides of the book, gives the binding solidity and precision as well as a professional look of high level to the finished product.

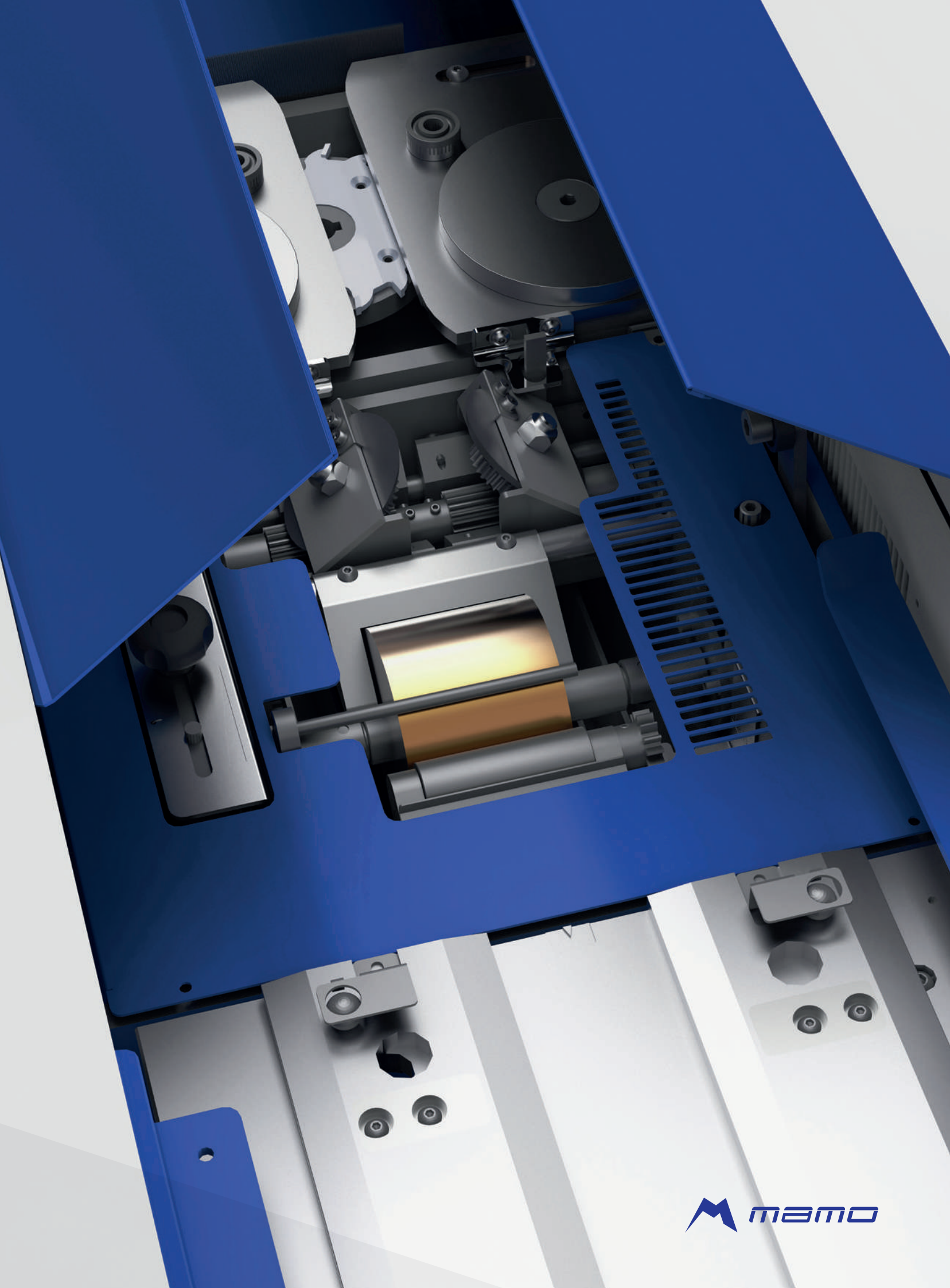

# Technical features

Ligo	
Maximum spine length	420 mm
Maximum book block thickness	50 mm
Minimum book block thickness	1 mm
Binding productivity with cover	180 books/hour
Work cycle speed adjustment	Automatic
Side gluers	Yes, adaptive
Book clamp closure adjustment	Yes, electric
Notching depth adjustment	Yes, electric
Soft covers weight	70 - 500 gr/m <sup>2</sup>
Hard covers thickness	Up to 2.8 mm
Maximum cover size	700 x 420 mm
Power supply	230VAC – 50/60Hz
Electrical absorption	2500 W
Dimensions (WxDxH)	1400 x 634 x 1364 mm
Weight	280 kg



### **Electrostatic and mobility**

Thanks to the ESD wheels, peaks in tension are discharged in a controlled manner, without any consequences. Smart mobility increase worker productivity and more efficient space organization

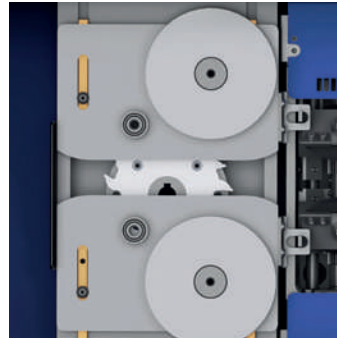

### **Milling and notching:**

Optimizes and favors the strength of the binding resulting in a better page hold and a higher quality finished product.



### **Smoke extractor:**

This is an exclusive system designed by Mamo, able to be connected up to an external extractor.

